

HOW TO ORDER

PROCESS CONTROLLERS

Slimline Ordering Code

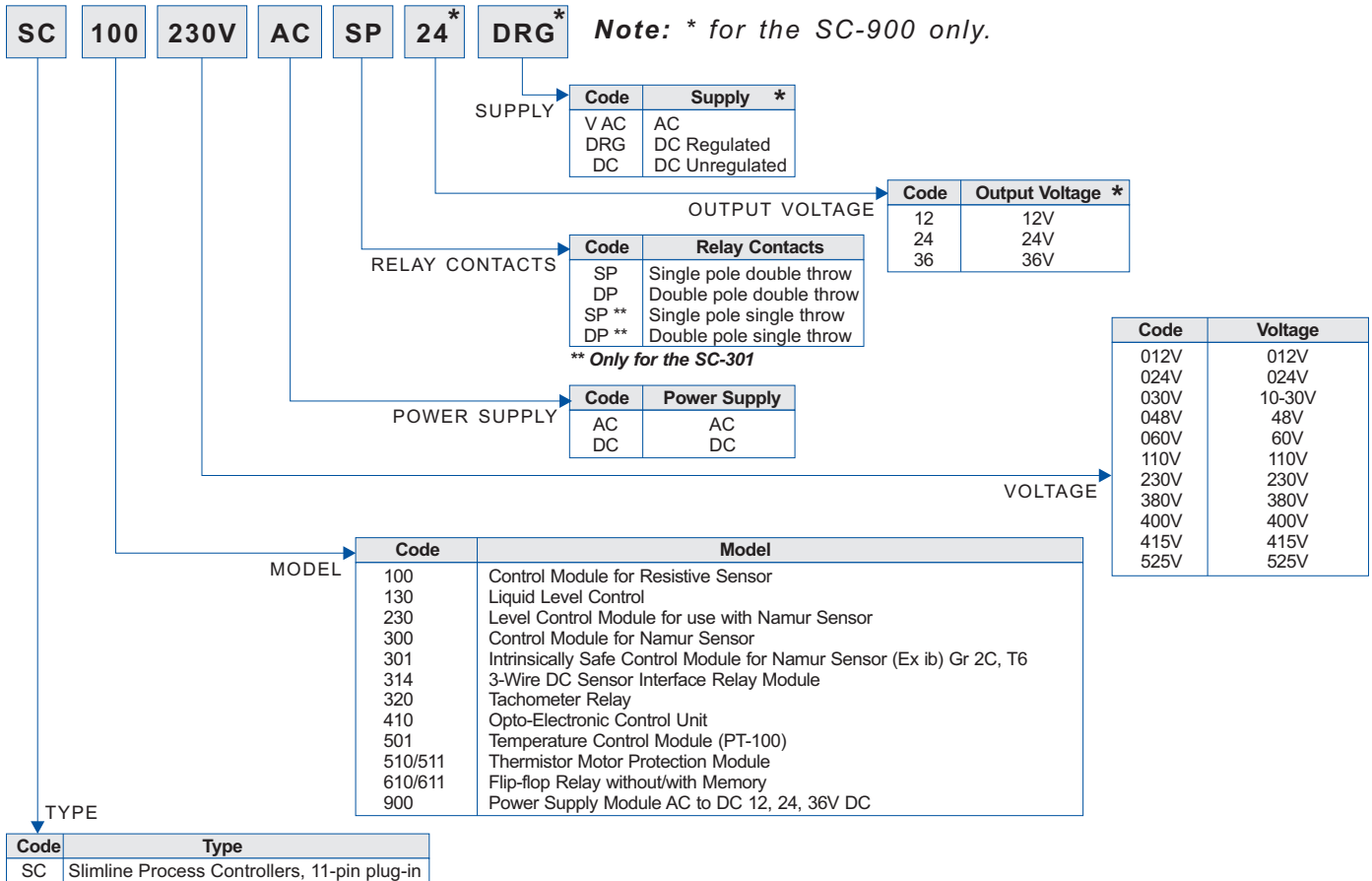

A-line Ordering Code

